

OL 730-8 Reflex Microscope

The OL 730-8 Reflex Microscope converts the Optronic Laboratories' series of light measuring instruments into either microphotometers, microradiometers, or microspectoradiometers. The reflex microscope enables these instruments to measure the luminance, radiance, or spectral radiance of very small, diffusely emitting sources. The useful spectroradiometric wavelength range with the achromatic lens is 360 to 1100 nm.

The OL 730-8 consists of an achromatic objective lens in a standard threaded mount, a baffle, and a reflex viewer compartment. A 10X power objective lens is standard with 5X and 20X objectives available as options. The reflex viewer has a 25 mm, three element, orthoscopic eyepiece. This wide-field eyepiece has a precision reticle with ten concentric circles ranging from 1 to 10 mm in diameter. FOV (field of view) apertures of 5, 3, and 1.5 mm are standard, with 0.5 mm available as an option.

A mounting flange for attaching the OL 730-8 directly to the monochromator is provided, along with a removable adaptor ring for coupling a detector directly to the reflex microscope. Coupling of the reflex microscope to the monochromator is also possible using the OL 730-7G Fiber Optic Probe. The OL 730-8 includes a fitting for convenient mounting to tripods or X-Z focusing stages.

Approximate photometric sensitivities when the OL 730-8, with 5X objective lens and various FOV apertures, is used with the OL 730C Programmable Radiometer/Photometer and OL 730-5A Detector/730-5-PF-LED Photopic Filter combination are:

<u>FOV Aperture</u>	<u>Target Area</u>	<u>Noise Equivalent Luminance(Cd/m²) with/Silicon Detector</u>
5.0 mm	1000 μm	1.6 x 10 ⁻³
3.0 mm	600 μm	4.3 x 10 ⁻³
1.5 mm	300 μm	1.8 x 10 ⁻²
0.5 mm	100 μm	1.6 x 10 ⁻¹

Approximate spectroradiometric sensitivities when the OL 730-8, with 10X objective lens and 3 mm FOV aperture, is used with the OL 750S Automated Spectroradiometric Measurement System are:

<u>Wavelength</u>	<u>Noise Equivalent Radiance (W/Ster cm² nm)</u>	
	<u>w/Silicon Detector</u>	<u>w/PMT Detector</u>
400 nm	2 x 10 ⁻⁹	7 x 10 ⁻¹³
600 nm	5 x 10 ⁻¹⁰	1 x 10 ⁻¹²
800 nm	4 x 10 ⁻¹⁰	8 x 10 ⁻¹²
900 nm	5 x 10 ⁻¹⁰	N/A

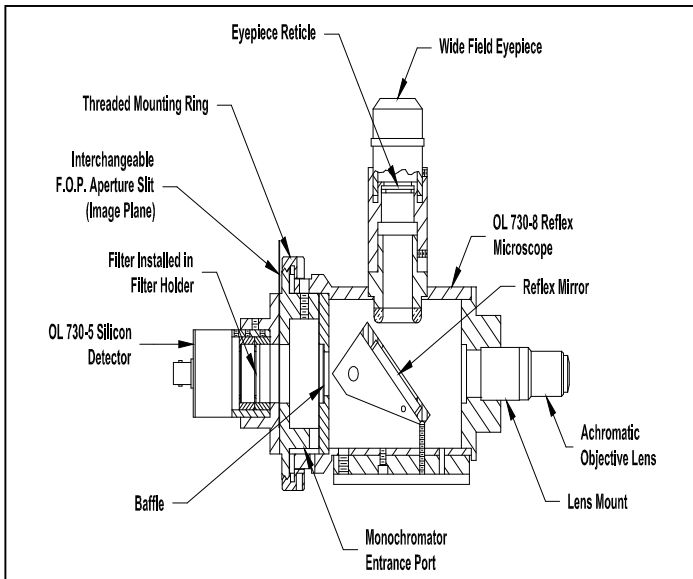

OL 730-8 Microphotometer/ Microradiometer Configuration

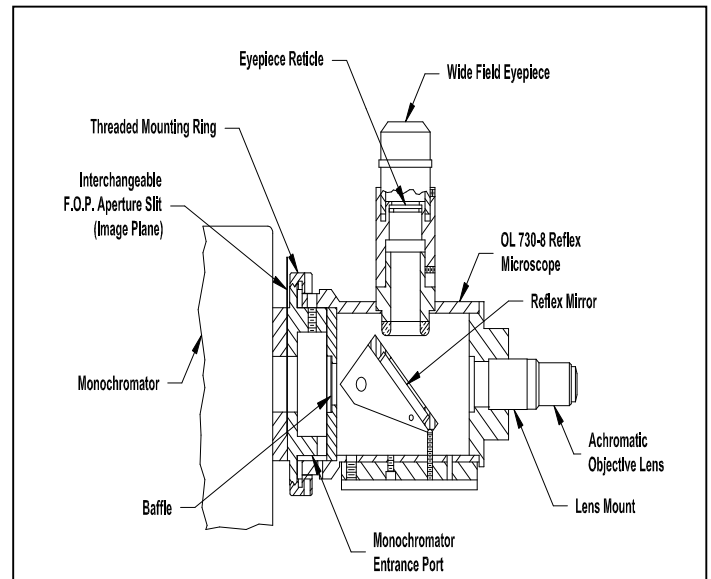

OL 730-8 Microspectoradiometer Configuration



OPTRONIC LABORATORIES

A Gooch & Housego Company

Optronic Laboratories, Inc. 4632 36th Street, Orlando, FL 32811
Tel: 1 407 422 3171 Fax: 1 407 648 5412 Email: info@olinet.com

Bulletin 71 / Rev. 3-06