

OL 700-30

Goniometric Measurement Assembly



The OL 700-30 Goniometric Measurement Assembly (goniometer) is designed to operate with the OL 770-LED High-speed Multichannel LED Test & Measurement System. The OL 770-LED Windows[®]-based application software provides complete control of the OL 700-30 goniometer with a comprehensive suite of spatial radiation measurement routines.

The OL 700-30 goniometer also features ActiveX[™] controls and Software Developers' Kit (SDK) as standard. This enables the instrument to accommodate custom applications as developed by the user, including applications independent of the OL 770-LED.

The lightweight, small footprint design makes the OL 700-30 ideal for QA and production floor DUT spot checks.

FEATURES

- Comprehensive suite of spatial radiation distribution measurements
- High speed USB Interface
- Powerful measurement software included
- Graphical presentation of any parameter vs. angle
- Easily customizable with ActiveX[™] controls
- Light-weight, small footprint design
- Conforms to CIE Publication 127 Condition A for Averaged LED Radiant Intensity Measurements *

Measurements Include

- View Angle
- Maximum intensity vs. angle
- Chromaticity vs. Angle
- Tristimulus vs. angle
- Lab/Luv vs. angle
- CRI vs. angle
- Relative power vs. angle
- Peak wavelength vs. angle
- Dominant wavelength vs. angle
- Half bandwidth vs. angle
- Color temperature vs. angle
- Purity vs. angle
- Power vs. angle

* Requires OL 15AB LED Receptor or OL 700-30A Condition A Tube



OPTRONIC LABORATORIES

A Gooch & Housego Company

Optronics Laboratories, Inc. 4632 36th Street, Orlando, FL 32811
Tel: 1 407 422 3171 Fax: 1 407 648 5412 Email: info@olinet.com

Bulletin 99 / Rev. 12-04

OL 700-30

Goniometric Measurement Assembly

SPECIFICATIONS

Automated horizontal range, θ	-90° to +90°
Minimum horizontal angle resolution	0.01°
Angular Accuracy *	0.001°
Maximum horizontal rotation rate @ 1° measurement interval	15° per second
Manual axial range, ϕ	-90° to +90°
Minimum horizontal angle resolution	10°
Computer interface	USB
Power requirement	External 12 VDC / 800mA main adapter (supplied)
Single linear positioning stage with center of rotation tool	≤ 12 mm linear travel
Test device interface	Banana jack (3)
Outputs	TTL trigger output to measurement device (BNC)
Dimensions	12.5" (31.75 cm) X 6.5" (16.51 cm) X 8" (20.32 cm)
Weight	14.5 lbs. (6.6 kg)
Enclosure	Black anodized aluminum, light resistant enclosure

* Accumulative error for each movement (start – stop) with allowance for backlash

Software Features

- Graphical presentation of any parameter vs. angle
- Automated view angle calculation
- Toggle from spatial graph to spectral scan at any angle
- Send plots/data to MS Word®
- Send data to MS Excel®
- Goniometric file save/load
- Polar plot cursors controlled by mouse
- Cursor difference measurements
- Peak snap cursor function
- CIE plot at each angle

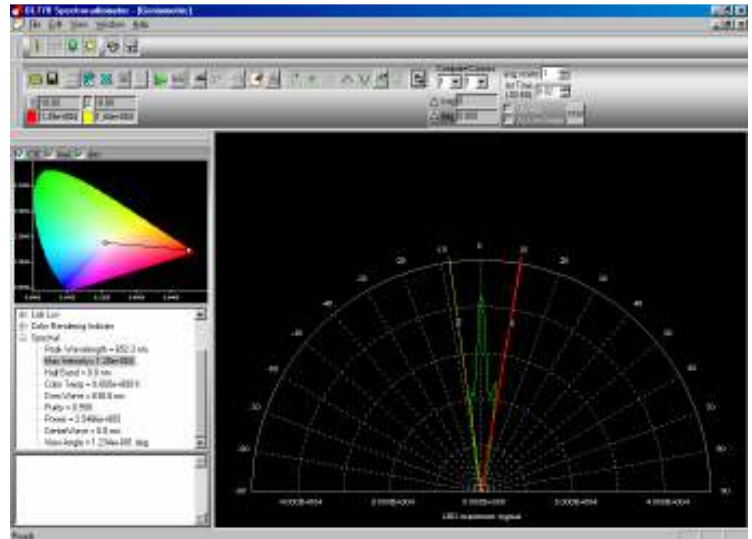

Spatial Scan of Red LED – Maximum intensity vs. angle

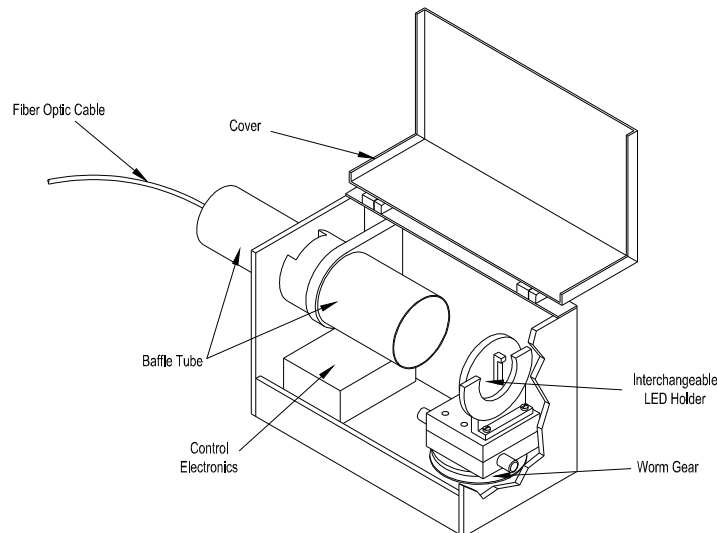

OPTRONIK LABORATORIES

A Gooch & Housego Company

Optronik Laboratories, Inc. 4632 36th Street, Orlando, FL 32811
Tel: 1 407 422 3171 Fax: 1 407 648 5412 Email: info@olinet.com

Bulletin 99 / Rev. 12-04